

金属板材加工柔性制造单元和系统 Sheet Metal Flexible Manufacturing Unit and System

**Yawei** 亚威

股票代码 002559

Stock Code 002559

# 自动化 事半功倍

Automation Get Twice the Result with Half the Effort

## 产品目录 Product Catalogue

自动化 事半功倍	02
Automation Get Twice the Result with Half the Effort	
钣金柔性加工系统	04
Sheet Metal Flexible Manufacturing System	
生产线	06
Production LineSheet	
下料单元	12
Sheet Cut Unit	
成型单元	18
Form Unit	
三维五轴激光切割机	22
3D five-axis laser cutting machine	
三维五轴充气柜激光焊接机	24
Five-axis laser welding machine	
选配-功能部件	26
Optional-Function Part	
客户案例	30
Customer Installations	

多年来，亚威股份一直致力于金属板材加工自动化，智能化，追求更多功能，更低能耗和最少的维护费用。我们拥有全系列的钣金加工成套设备，根据您的需求，可以为您量身定制，提供全程的解决方案；我们拥有全球销售服务网络，为您提供周到快捷的服务。

Over the years, Yawei has been dedicated to sheet metal processing automation, intelligence, pursues more functions, less power consumption and minimal maintenance costs. We have a full range of sheet metal processing equipment. Based on your needs, we can be customized for you, and provide you with full solutions. We have a worldwide sales and service network, to provide you with thoughtful and efficient service.

## 你能得到 You Can Expect

当新的需求变化来临时，柔性加工具有提高生产效率和多种加工手段

When change and new demand comes, flexible manufacturing has the feature of improved productivity and a variety of processing methods

- 更小的厂房与占地面积，同时提供更高的产能
- 将改动设定的时间缩至最短
- 更少的储存空间和半成品制造流程
- 快速并自动实施制造工件的转换
- 高等级并且平均的零件质量
- 缩短交货期并适应新产品的需求
- 不因物流安排失误致使产能损失
- Less space occupied, higher capacity
- Minimized setting time for changes
- Less storage space and semi-finished products manufacturing processes
- Quick and automatic converting between work piece
- High grade and average quality of the parts
- Shorten delivery time and meet the needs of new products
- No loss caused by logistical arrangement errors



更低的能耗 更高的回报

Higher Returns with Less Power Consumption

Yawei金属板材柔性制造系统是建立在柔性制造单元（冲压单元、冲剪单元、折弯单元等）基础上，配有大型立体仓库，自动上下料，分选码垛装置以及其他辅助装置，由数控系统对各单元及全线实现自动控制，24小时的无人化生产已不再是梦想；大型料库实现金属板料及工件的自动输入、输出和储存；繁琐耗时的材料搜索由系统自动完成，繁重的人工上下料搬运由上下料装置取代；完成的工件无需手工分拣，自动分拣系统可为您代劳。您不仅节约了人工成本，更提高了设备生产效率。

丰富的加工信息提示及强大的自诊断信息极大地方便了用户对整条线的自我维护，并极大的提高了整条线的安全可靠性。

先进的信息管理技术更是对钣金加工制造的过程管理，并可与客户的生产管理系统及技术研发网络进行无缝连接，提高设备使用效率。

Yawei sheet metal flexible manufacturing system is based on flexible manufacturing unit (punching unit, punching & shear combi, press brake unit, etc.), equips with a large material library, automatic loading and unloading, sorting and stacking devices and other assistant devices. Each unit and whole system automatically controlled by CNC system, making 24-hour production without human no longer a dream. The large material library realizes automatic input, output and storage of the sheet and work piece. Cumbersome and time-consuming searching for material is done automatically by the system. Heavy manual loading and unloading handling is replaced by automatic loading and unloading system. Instead of manual sorting, the finished parts will be sorted by sorting system automatically. Not only save labor costs, but also improve the efficiency of production equipment.

Abundant processing information tips and powerful information self-diagnostic greatly facilitate the user to maintain the entire system, and greatly improve the safety and reliability of the whole system.

Advanced information management technology also strengthens the sheet metal manufacturing process management, and can be seamlessly connected with the customer's production management system and technology R & D network, Improve the use efficiency of equipment.



# 钣金柔性加工系统 (FMS)

Sheet Metal Flexible Manufacturing System (FMS)

全能型金属板材柔性制造系统 (FMS) 按照特定的工艺需求, 将各金属板材制造单元统筹运行, 对物流进行自动化管理。此系统整合了亚威股份各类高性能的钣金加工机床、机器人应用技术和数据处理技术。由于系统组合方式的模块化和多样化, 使得此系统可以广泛应用于各类金属板材的自动化生产。

Sheet metal flexible manufacturing system(FMS), designed on the base of dedicated process requirements, integrates the running of each sheet metal flexible manufacturing cell, controls the logistics automatically. This system integrates various types of high-performance sheet metal processing machine tools, robot application technology and data processing technology from Yawei. Due to the modular system and diverse combinations, this system can be widely used in various kinds of sheet metal automation production.

可专门设计制造特殊工件的生产线

Specially designed production line for particular work piece

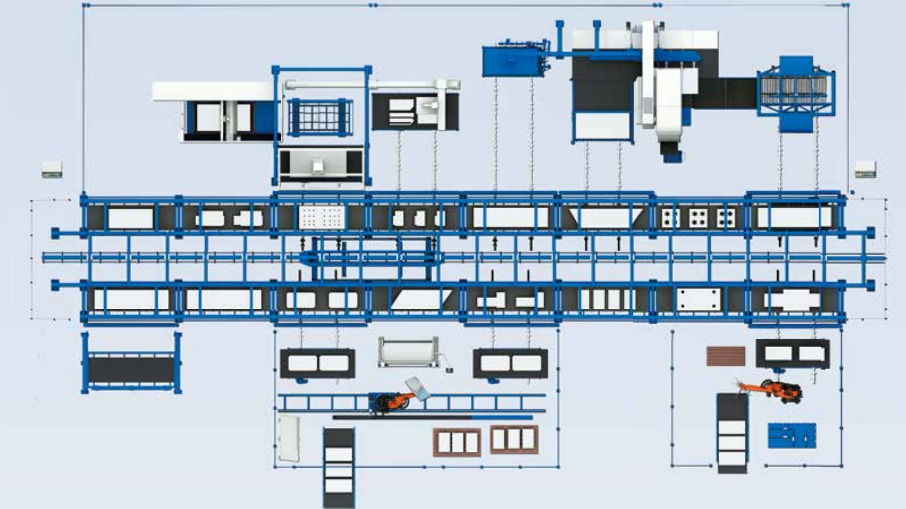

- ① 智能进出料单元
- ② 智能码垛单元
- ③ 直角裁剪单元
- ④ 高性能伺服冲床
- ⑤ 智能上料单元
- ⑥ 伺服折弯机
- ⑦ 废料分离单元
- ⑧ 对中台
- ⑨ 翻面架
- ⑩ 六轴机器人
- ⑪ 智能大型料库
- ⑫ 平推式下料装置
- ⑬ 激光切割机
- ⑭ 智能取料单元
- ⑮ 出料传送带

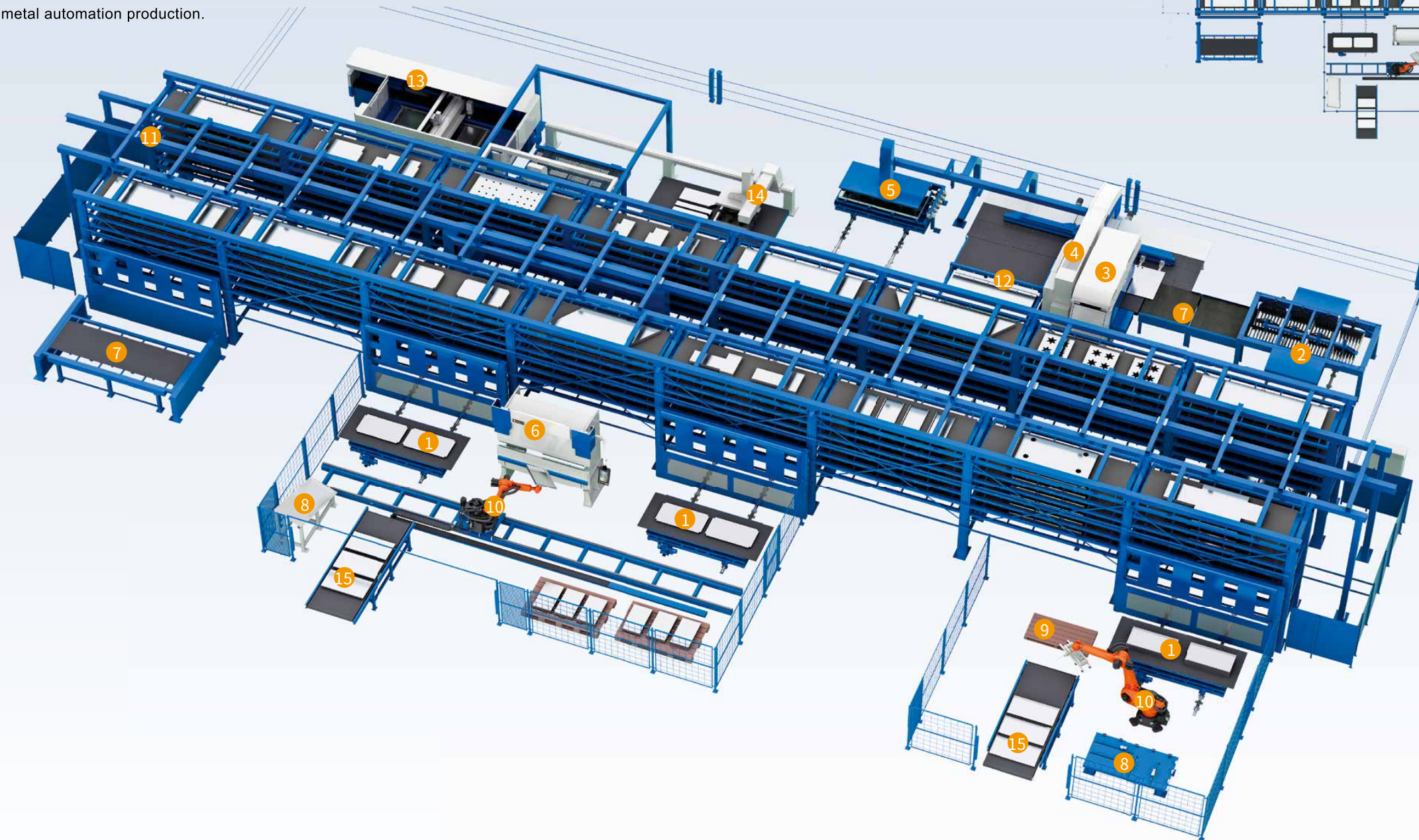

- ① Intelligent input & output unit
- ② Intelligent stacking unit
- ③ Right angle shear
- ④ Servo turret punch
- ⑤ Intelligent loading unit
- ⑥ Servo pressbrake
- ⑦ Scrape separation unit
- ⑧ Centering table
- ⑨ Turn-over frame
- ⑩ 6-axis robot
- ⑪ Intelligent material library
- ⑫ Pushing type unloading device
- ⑬ Laser cutting machine
- ⑭ Intelligent material picking unit
- ⑮ Discharging conveyor



# 生产线——钣金柔性加工

## Production LineSheet —— Metal Flexible

钣金柔性加工生产线是一种紧凑、灵活的生产线，整合了立体仓库、数控冲剪单元、对开码垛装置、翻面装置和数控板料折边单元，可全自动的将平板坯料进行冲剪和折边加工。整套生产线生产量大、占地面积小，能够进行高柔性、全自动物料处理，无需人工干预。

Sheet metal flexible production line is a compact and flexible production line, which integrates material library, punch and shear combi unit, split stacking device, turn-over device and CNC panel bender unit. It can automatically punching and flanging the sheet metal blank. The whole production line has the advantages of large production capacity, small area covering, high flexibility, full-automatic material processing, and no human intervention required.

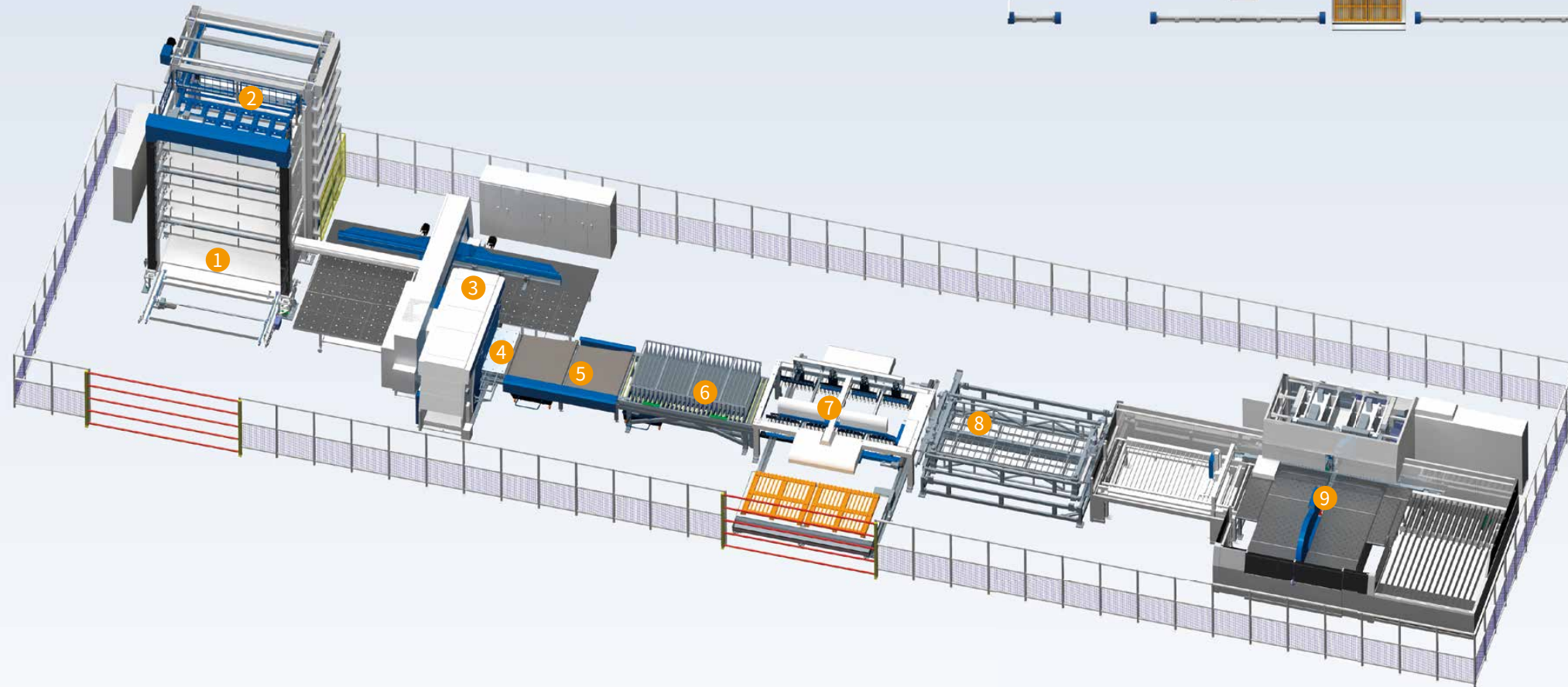
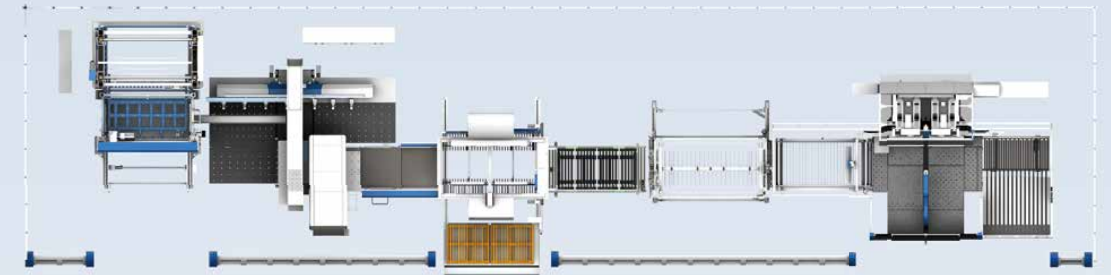

- ① 智能立体板料库
- ② 单张取料装置
- ③ 伺服转塔冲床
- ④ 伺服直角剪
- ⑤ 分拣落料装置（标配两级）

- ⑥ 对开码垛装置
- ⑦ 出料缓存装置
- ⑧ 翻面装置
- ⑨ 数控板料折边单元

- ① Intelligent 3D material library
- ② Single sheet feeder device
- ③ Servo turret punch
- ④ Servo right angle shear
- ⑤ Sorting blanking device(standard two steps)

- ⑥ Split stacking device
- ⑦ Discharge buffer device
- ⑧ Turn-over device
- ⑨ CNC panel bender unit

# 生产线——AMS.HSP系列板料冲剪折自动化

Production LineSheet —— AMS.HSP Series Sheet Punch & Shear & Bend Combo

AMS.HSP系列板料冲剪折弯自动化加工系统将冲剪单元和机器人折弯单元整合在一起，可完成金属板材的自动冲压、剪切、折弯和码垛。

AMS.HSP series sheet punch & shear & bend combo system, integrates the punch & shear unit and robot bending unit, to realize the automatic sheet punching, shearing, bending and stacking.

## 适用场合

- 大批量零件生产
- 工件需要翻面折弯
- 冲压折弯工艺较复杂
- 工件尺寸规格变化较大

## 工艺特点

- 冲剪出料缓存，缓解冲剪与折弯效率不匹配问题
- 原板料不需要定尺板料

## Occasions applicable

- Accessory volume-production
- Work pieces with turn-over bending
- Complex punching and bending process
- Large dimension range of work piece

## Features

- Unloading buffer to relief the mismatching between punch & shear and bending
- No need for sheets of specified dimension

- ① 冲剪单元      ① Punch & shear unit
- ② 折弯单元      ② Bending unit

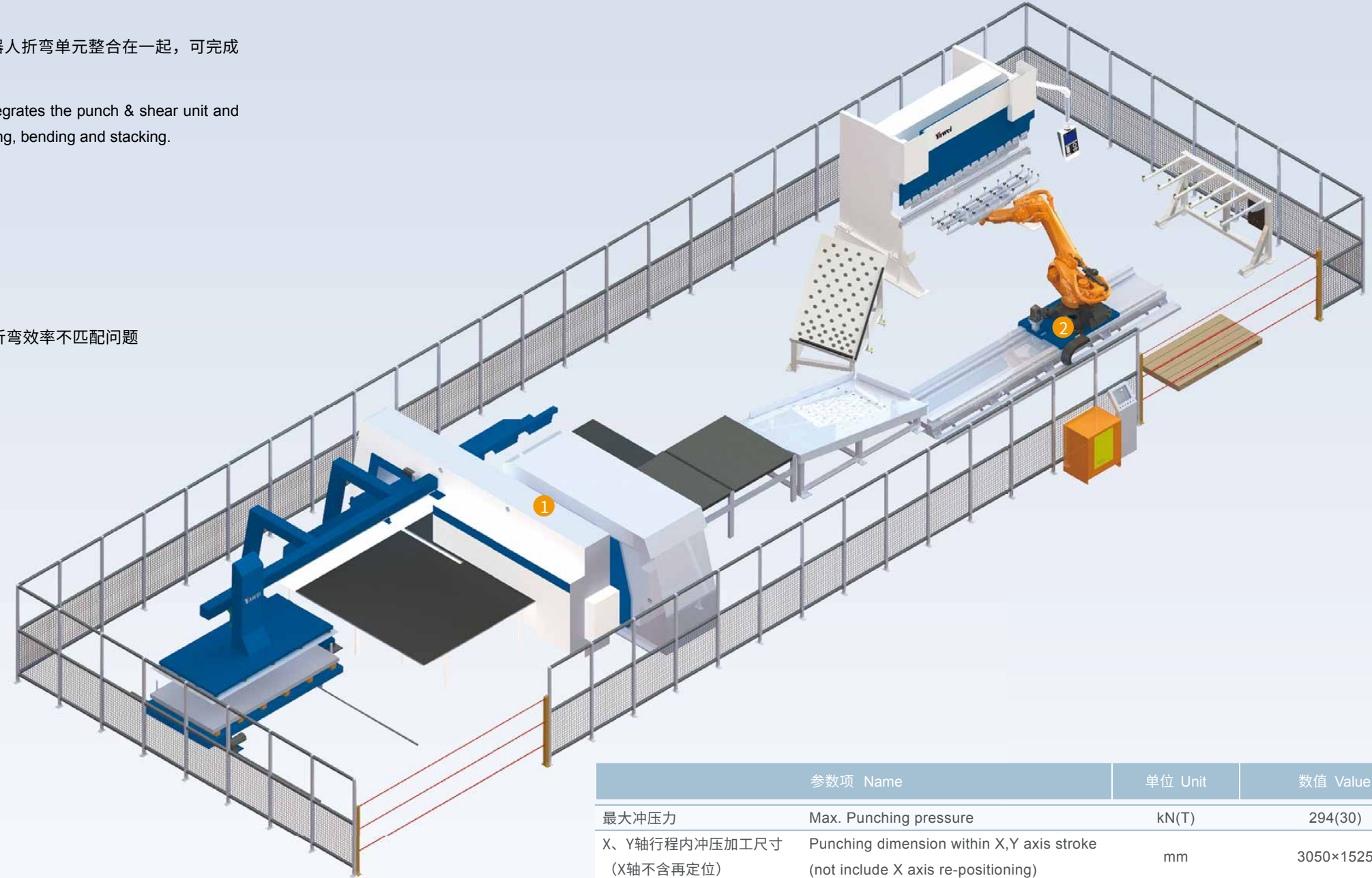

参数项 Name	单位 Unit	数值 Value
最大冲压力	Max. Punching pressure	kN(T) 294(30)
X、Y轴行程内冲压加工尺寸 (X轴不含再定位)	Punching dimension within X,Y axis stroke (not include X axis re-positioning)	mm 3050×1525
X、Y轴行程内剪切加工尺寸 (X轴不含再定位)	Shearing dimension within X,Y axis stroke (not include X axis re-positioning)	mm 2500×1500
最大加工板料厚度 (Q235A)	Max. Sheet processing thickness (Q235A)	mm 6.35 (冲压 punching) 4 (剪切 shearing)
机器人负载	Robot loading capacity	kg 210
机器人轴数	Robot axis	6+1



# 生产线——电梯门板柔性生产线

## Production LineSheet —— Elevator Door Panel Flexible

本加工系统的目的是提高电梯门板、轿壁等大型平板钣金件折弯的柔性自动化生产程度，整个系统包括：原料板材由自动上料系统抓取，转到数控冲床完成冲压加工，加工后的板材分别由两台龙门式折弯机器人和两台折弯机完成长边和短边折弯加工。折完短边后，转运至焊接输送线，依次完成加强筋电阻焊接、伺服电弧焊接加强筋与底板搭边处、机器人点焊底板各搭边处并码垛于木质托盘上。

The automatic processing system is used to raise the automation level of those large sheet metal parts, e.g. elevator door, car enclosure, etc. The system actions includes: the grabbing of raw material, the punching on CNC turret punch, the bending by two sets of gantry robots and press brakes. When the bending of short edge finishes, convey the work piece to welding components, to do the welding process and finally stack on the wooden tray.

- ① 自动上料抓手
- ② 数控冲床
- ③ 数控折弯机（长边）
- ④ 龙门式折弯机器人
- ⑤ 数控折弯机（短边）
- ⑥ 焊接输送线
- ⑦ 加强筋安装系统
- ⑧ 加强筋料库
- ⑨ 加强筋龙门电阻焊
- ⑩ 清枪站
- ⑪ 焊接码垛机器人
- ⑫ 木制托盘
- ⑬ 电气控制系统

- ① Loading manipulator
- ② CNC turret punch
- ③ CNC pressbrake (long edge)
- ④ Gantry robot type
- ⑤ CNC press brake (short edge)
- ⑥ Welding conveyor line
- ⑦ Reinforce rib installation system
- ⑧ Material library for reinforce rib
- ⑨ Electric resistance welding for reinforce rib
- ⑩ Welding gun cleaning station
- ⑪ Welding & stacking robot
- ⑫ Wooden tray
- ⑬ Electrical controller

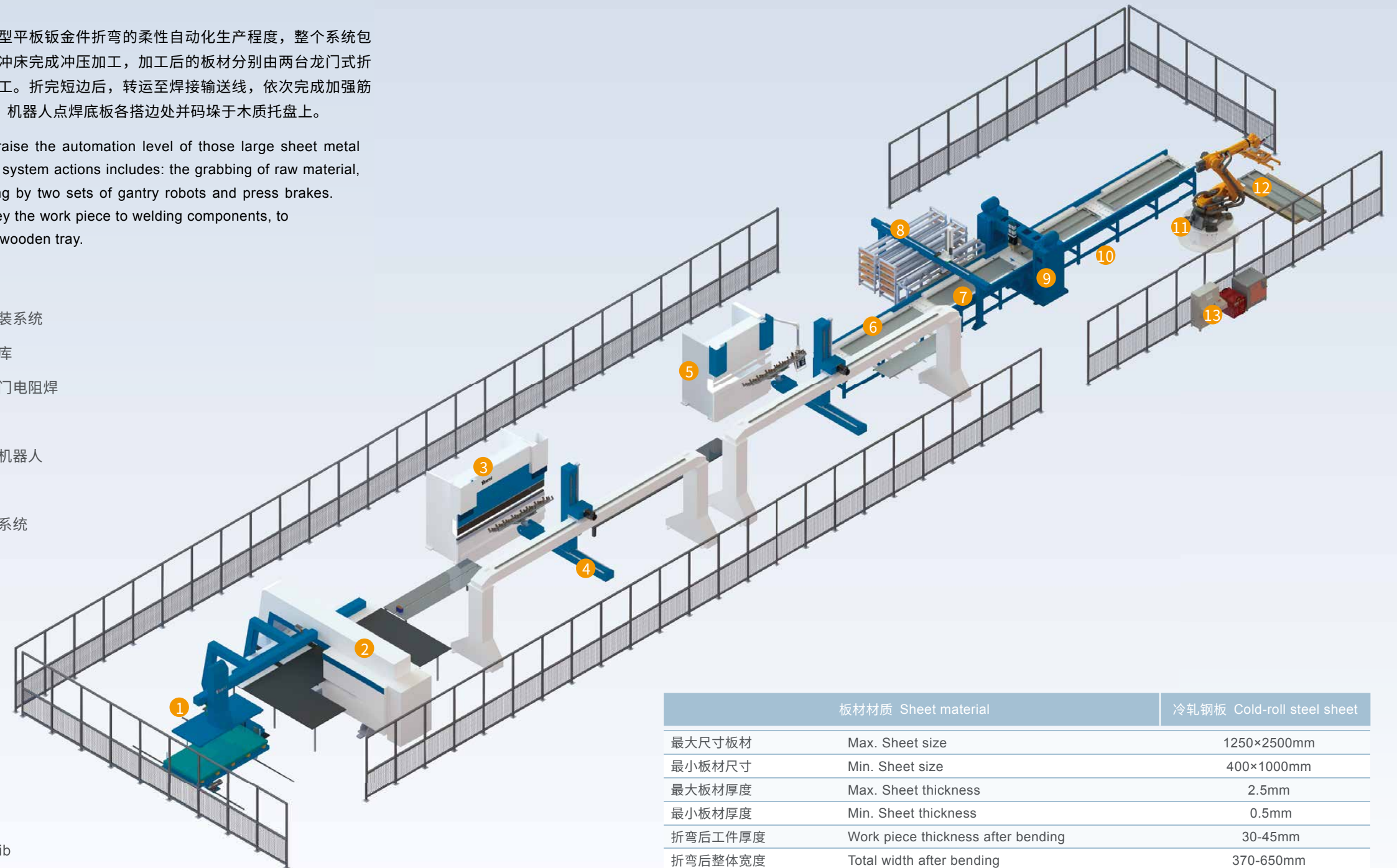

	板材材质 Sheet material	冷轧钢板 Cold-roll steel sheet
最大尺寸板材	Max. Sheet size	1250×2500mm
最小板材尺寸	Min. Sheet size	400×1000mm
最大板材厚度	Max. Sheet thickness	2.5mm
最小板材厚度	Min. Sheet thickness	0.5mm
折弯后工件厚度	Work piece thickness after bending	30-45mm
折弯后整体宽度	Total width after bending	370-650mm
上料固定工作台最大载重	Max. Capacity of loading worktable	2000kg
上料台车最大堆高	Max. Stacking height of loading pallet	300mm
上料台车最大载重	Max. Loading capacity of loading pallet	2000kg
加强筋与底板焊点距离	Distance between reinforce rib and welding point	250-300mm

## 下料单元——AMS.HS冲剪单元

Sheet Cut Unit —— AMS.HS Punch & Shear Combi Unit

冲剪单元可以整合智能立体板料库、冲剪复合机、上料装置、分拣出料装置和自动分选堆垛机，可自动完成金属板材的出料、冲压加工、剪切加工和自动分选堆垛；集中控制系统合理控制各加工主机，使系统的加工效率最大化。

Punch & Shear combi unit can integrate the intelligent material library, punch & shear combi machine, feeding device, sorting and discharging device and automatic sorting and stacking machine, and can automatically complete the discharging, punching, shearing and automatic sorting and stacking of plates; the centralized control system can reasonably control each processing device to maximize the processing efficiency of the system.

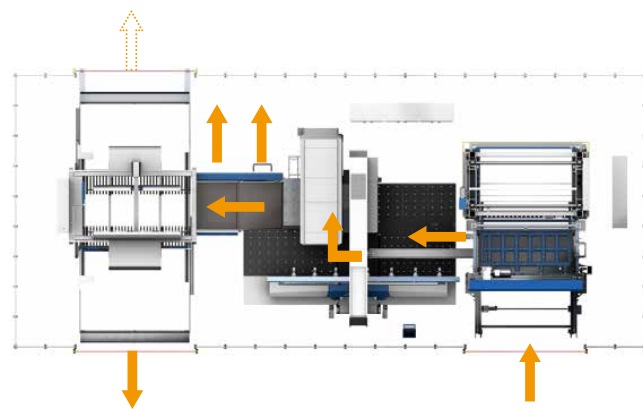
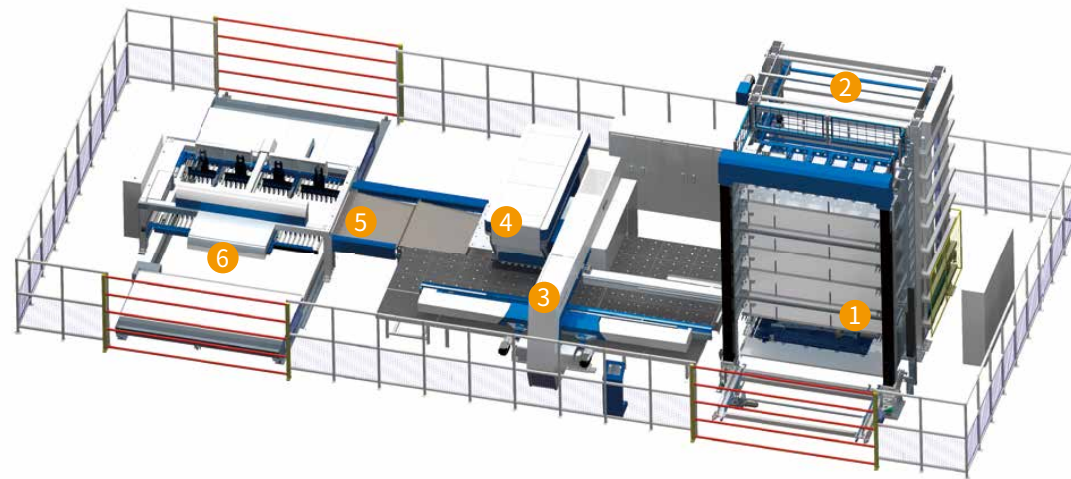

- ① 智能立体板料库 (选配)
  - ② 单张取料装置 (选配)
  - ③ 伺服转塔冲床
  - ④ 伺服直角剪
  - ⑤ 分拣落料装置 (标配两级)
  - ⑥ 自动分选堆垛装置 (选配)
- ① Intelligent 3D material library (option)
  - ② Single sheet feeder device (option)
  - ③ Servo turret punch
  - ④ Servo right angle shear
  - ⑤ Sorting and blanking device (standard two steps)
  - ⑥ Automatic sorting and stacking device (option)

## 下料单元——AMS.HL冲割单元

Sheet Cut Unit —— AMS.HL Punch & Laser Combi Unit

冲割单元综合了冲压加工和激光切割加工的工艺优点，既可以实现冲压成型、螺纹加工，也可以切割出平滑的轮廓曲线；既可以满足高精度的批量生产，也可以满足单件小批量的柔性生产。

The Punch & Laser Combi Unit integrates the advantages of punching and laser cutting. It can not only achieve punching forming, thread processing, but also cut out smooth contour curve; it can meet the requirements of high-precision batch production, as well as single piece small batch flexible production.

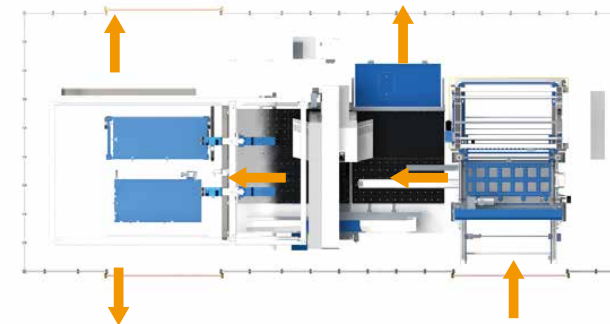
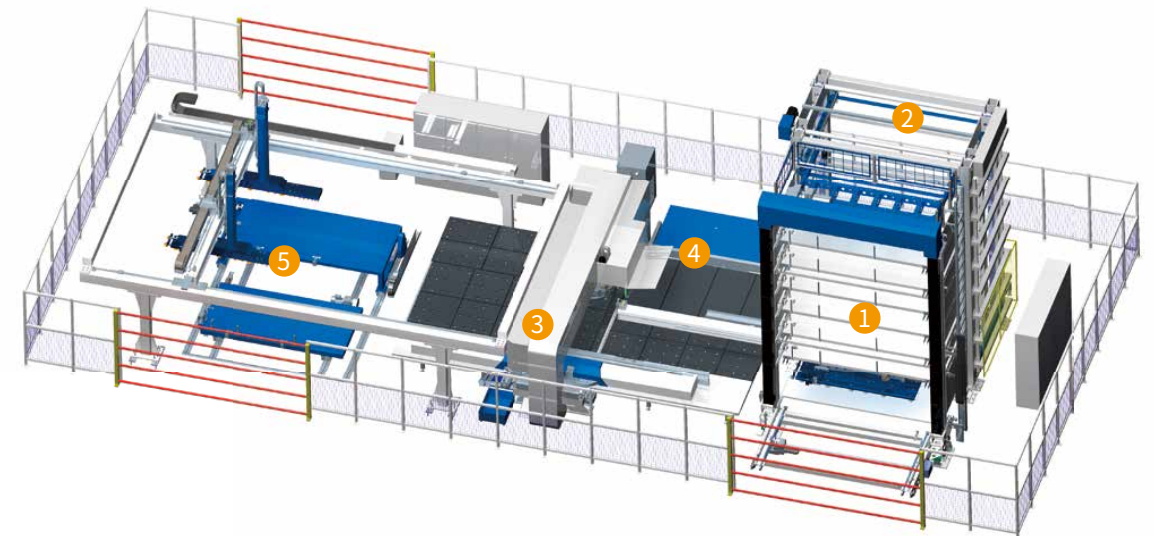

- ① 智能立体板料库 (选配)
  - ② 单张取料装置 (选配)
  - ③ 冲割复合机
  - ④ 废料下料装置
  - ⑤ 龙门码垛装置 (选配)
- ① Intelligent 3D material library (option)
  - ② Single sheet feeder device (option)
  - ③ Punch & Laser Combi machine
  - ④ Scrap unloading device
  - ⑤ Gantry stacking device (option)



## 下料单元——单侧型冲压单元

Sheet Cut Unit —— Single Side Punch Unit

冲床单侧型冲压单元(FMC)具备自动上料、冲压加工和自动下料堆垛功能，上料和下料装置集成在冲床一侧，占用场地少，效率高。

CNC Turret Punch single side punch unit (FMC) integrates automatic loading, punching processing and automatic discharging & stacking functions. Loading and unloading device is integrated at the same side, high efficient with less space.

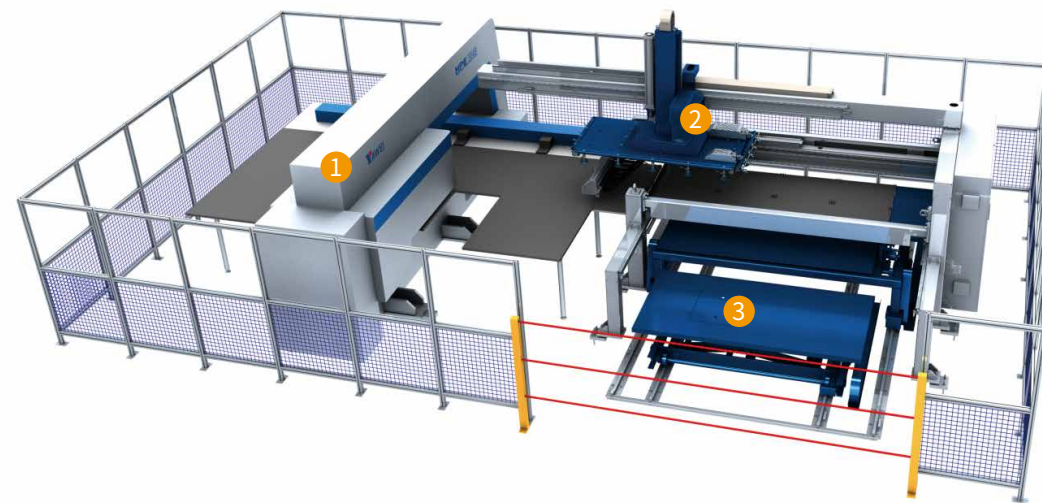

### 生产方式图

(虚箭头表示可以选择的出料方向)

Figure of production mode

(Virtual arrows indicate optional discharging direction)

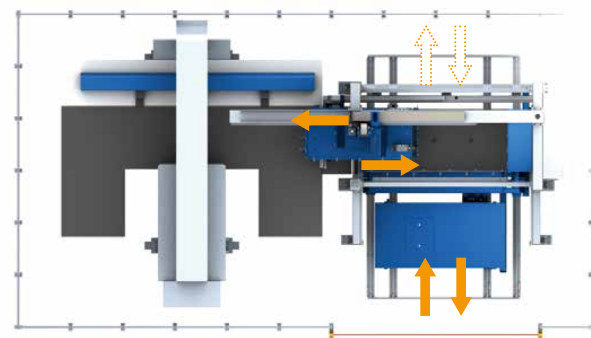

- ① 数控转塔冲床
  - ② 冲床单侧上下料装置
  - ③ 交互式上下料台车
- ① CNC Turret Punch
  - ② Single side loading and unloading device
  - ③ Interactive loading and unloading trolley

## 下料单元——双边型冲压单元

Sheet Cut Unit —— Double Sides Punch Unit

冲床双边型冲压单元具备自动上料、冲压加工和自动下料堆垛功能；上料装置和下料装置分别在冲床两边，可扩展性强；效率高。

CNC Turret Punch double sides punch unit (FMC) integrates automatic loading, punching process and automatic, discharging & stacking functions. Loading and unloading device is integrated at the different sides, high efficiency and scalability.

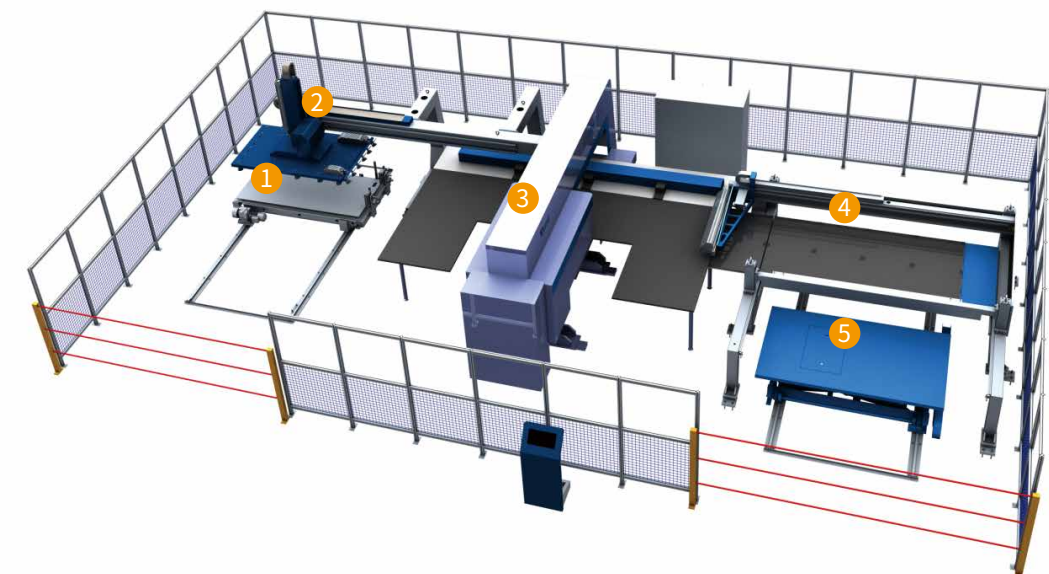

### 生产方式图

(虚箭头表示可以选择的出料方向)

Figure of production mode

(Virtual arrows indicate optional discharging direction)

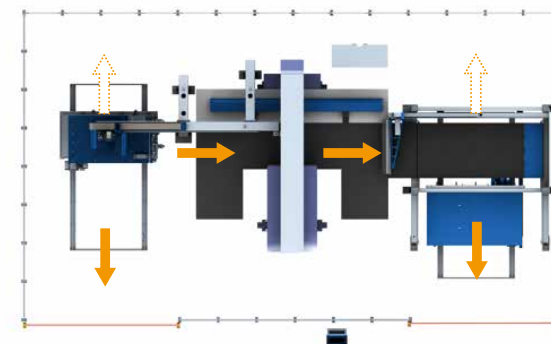

- ① 上料台车
  - ② 上料装置
  - ③ 数控转塔冲床
  - ④ 下料装置
  - ⑤ 下料升降台车
- ① Loading trolley
  - ② Loading device
  - ③ CNC Turret Punch
  - ④ Unloading device
  - ⑤ Unloading lifting trolley



# 下料单元——激光上下料单元

## Sheet Cut Unit —— Laser Loading Unloading Unit

亚威提供的激光切割自动化系统，可以作为智能钣金工厂的设备单元，与生产管理中心ERP/MES进行实时通讯和数据共享，按生产计划进行无人化加工。

Our automation system can be served as the unit of smart factory. Can be linked to the central control ERP/MES system to realize the real-time communication and data sharing, and processing under product plans without man.

### 激光切割单元 FMC Laser Cutting Unit FMC

- 自动完成板材的上料、切割和下料，实现单一规格板材的批量连续加工，显著提升了加工效率，降低了综合生产成本
- Loading, cutting and unloading automatically, Realize continuous batch processing for the single specification sheet, dramatically rise up the process efficiency and low down the production cost

- |           |                         |
|-----------|-------------------------|
| ① 原料台车    | ① Raw material cart     |
| ② 自动上下料装置 | ② Automatic LUL device  |
| ③ 激光切割机   | ③ Laser cutting machine |
| ④ 成品台车    | ④ Finished product cart |

### 激光切割柔性系统 FMS Laser Cutting Flexible System FMS

- 在上述FMC基础上增加多层料库系统，可进行多品种多规格板材的批量加工，并可与生产管理系统实现通讯和数据共享
- 可根据需要选配工件分拣系统
- Add the multi-shelves material storage system to the above FMC, it can realize the batch processing and sheets with different specifications, and date sharing with production management system
- According to the requirement, the workpieces sorting system can be selected

- |           |                                |
|-----------|--------------------------------|
| ① 多层料库    | ① Multi-shelves storage system |
| ② 原料台车    | ② Raw material cart            |
| ③ 自动上下料装置 | ③ Automatic LUL device         |
| ④ 激光切割机   | ④ Laser cutting machine        |
| ⑤ 成品台车    | ⑤ Finished product cart        |
| ⑥ 工件分拣系统  | ⑥ Sorting system               |

### 激光切割柔性生产线 FMS Laser Cutting Flexible Production Line FMS

- 由多层料库系统、多台激光切割主机、自动上/下料系统组成。大大提高了劳动生产效率和钣金工厂的自动化水平，促进制造业转型升级
- The multi-shelves material storage system, laser cutting machines and automatic loading/unloading device. It can improve production efficiency and automation level of the sheet metal factory, and contribute to transformation and upgrading of the manufacturing industry



自动上下料装置（上料吸盘机构/下料指状托料架）  
Sucking device for loading / finger support for unloading

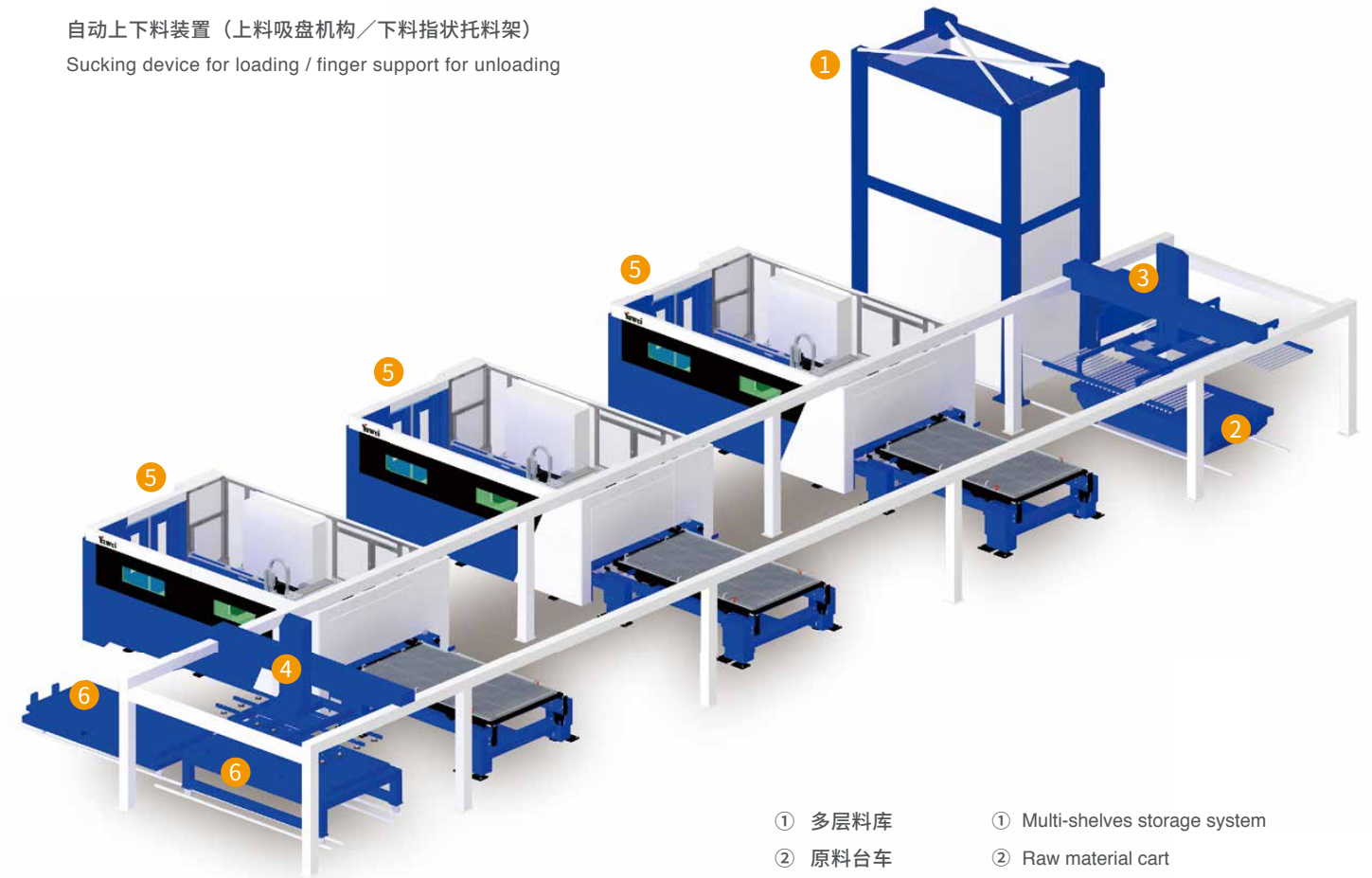

- |          |                                |
|----------|--------------------------------|
| ① 多层料库   | ① Multi-shelves storage system |
| ② 原料台车   | ② Raw material cart            |
| ③ 自动上料装置 | ③ Automatic loading device     |
| ④ 自动下料装置 | ④ Automatic unloading device   |
| ⑤ 激光切割机  | ⑤ Laser cutting machine        |
| ⑥ 成品台车   | ⑥ Finished product cart        |

# 成型单元——四边折边机

Form Unit —— CNC Panel Bender

数控板料折边机具有高柔性、高效率、高精度与自动化程度高的特点，适用于盒类、门类等类型零件的加工，广泛应用于厨房设备、开关电柜、暖通、电力电子、电梯等众多行业。

一套组合式自动模具系统可实现上折边、下折边、大圆弧、覆平折边等多种工艺，适应各种复杂零件的加工，根据工件尺寸和形状自由组合模具，高效换模，实现柔性化折边。

AMS.HSP series sheet punch & shear & bend combo system, integrates the punch & shear unit and robot bending unit, to realize the automatic sheet punching, shearing, bending and stacking.

AMS.HSP series sheet punch & shear & bend combo system, integrates the punch & shear unit and robot bending unit, to realize the automatic sheet punching, shearing, bending and stacking.

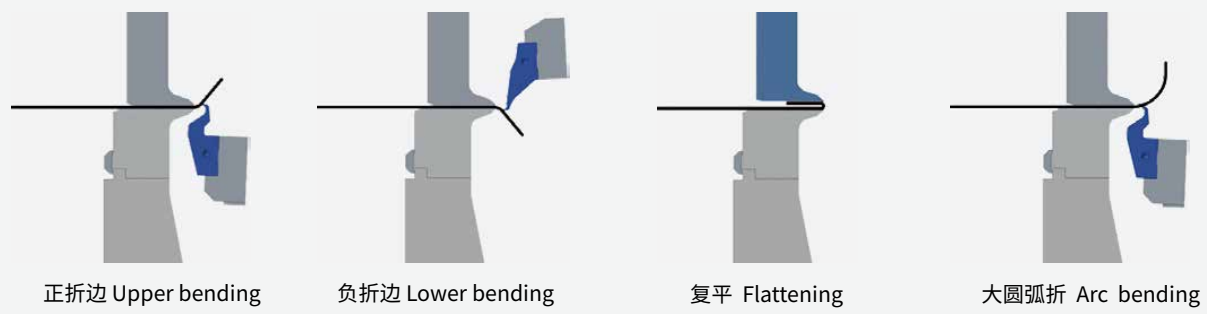

## 特点

- 高效率：采用快速折边技术
- 高精度：采用高刚性技术、高精度模具技术，折边精度高
- 高表面质量：两种折边模式可选，良好的表面质量
- 高柔性：采用正正反折自动换模+短刀模技术，具备圆弧、覆平、短边折等工艺功能
- 全自动：上料、折边、上料全自动完成
- 绿色节能：主运动采用伺服控制技术，节能环保

## Feature

- High efficiency: adopt the technology of fast folding
- High precision: high rigidity technology, high precision tool technology, high precision bending
- High surface quality: two bending modes, good surface quality
- High flexibility: adopt positive and negative folding automatic tool exchange + short tool technology, with arc, flattening, short edge bending and other functions
- Full automatic: loading, bending and unloading are completed automatically
- Energy saving: Main movement adopt servo control technology, energy saving and environmental friendly

参数项 Name		单位 Unit		数值 Value		
最大折弯长度	Max. bending length	mm		2500		
最大折弯高度	Max. bending height	mm		165		
最大对角尺寸	Max. diagonal dimension	mm		2800		
折弯厚度	Bending thickness	普通碳钢	MS	$\sigma_b=420\text{MPa}$	mm	3.2
		不锈钢	SS	$\sigma_b=660\text{MPa}$	mm	2.0
		铝板	AL	$\sigma_b=265\text{MPa}$	mm	4.0
最小折弯厚度	Min. bending thickness	mm		0.5		
工作台面高度	Height of worktable	mm		1000		
外形尺寸	Overall dimension	长	Robot rail stroke	L	mm	10700
		宽	Robot rail stroke	W	mm	6650
		高	Robot rail stroke	H	mm	2800
机器重量	Machine weight	Ton		35		

注：最大板厚为折90°时数据 Note: It is data for Max. thickness 90 degree bending

## 典型工件 Typical parts





## 成型单元——六轴机器人型

Form Unit —— 6-Axis Robot Type

## 成型单元——龙门机器人型

Form Unit —— Gantry Robot Type

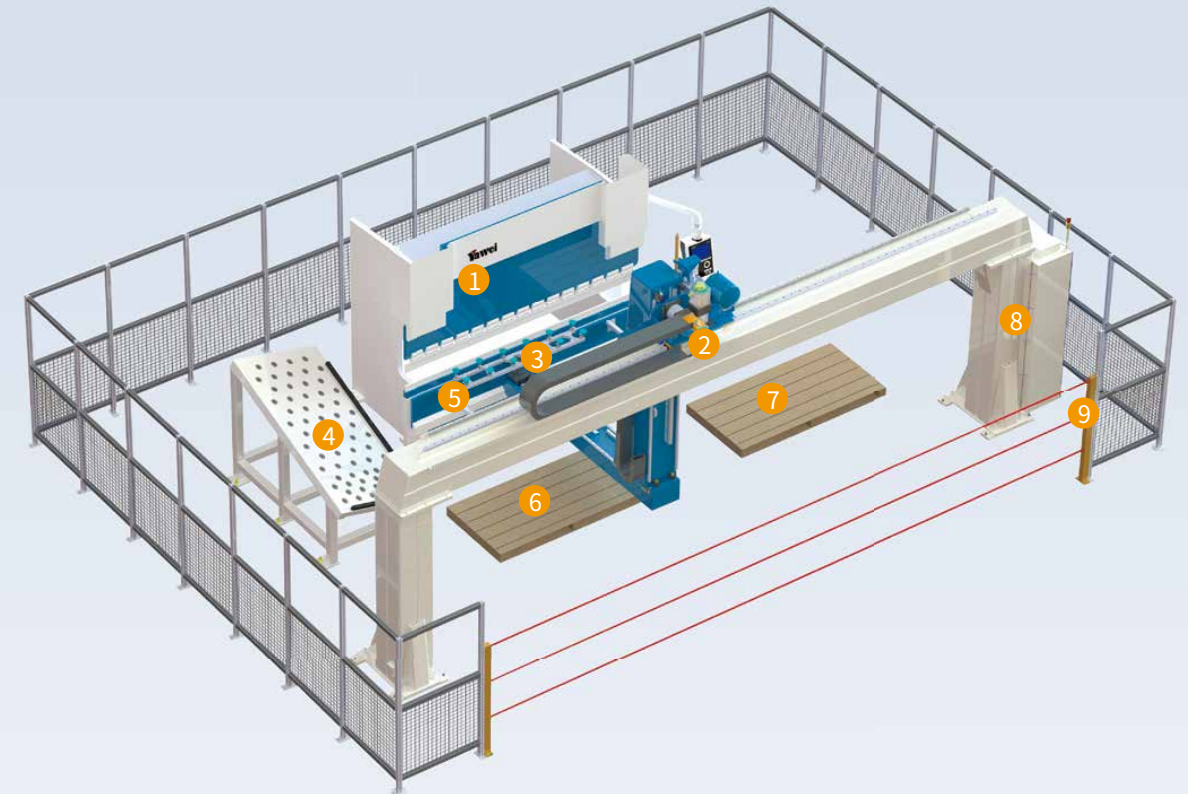
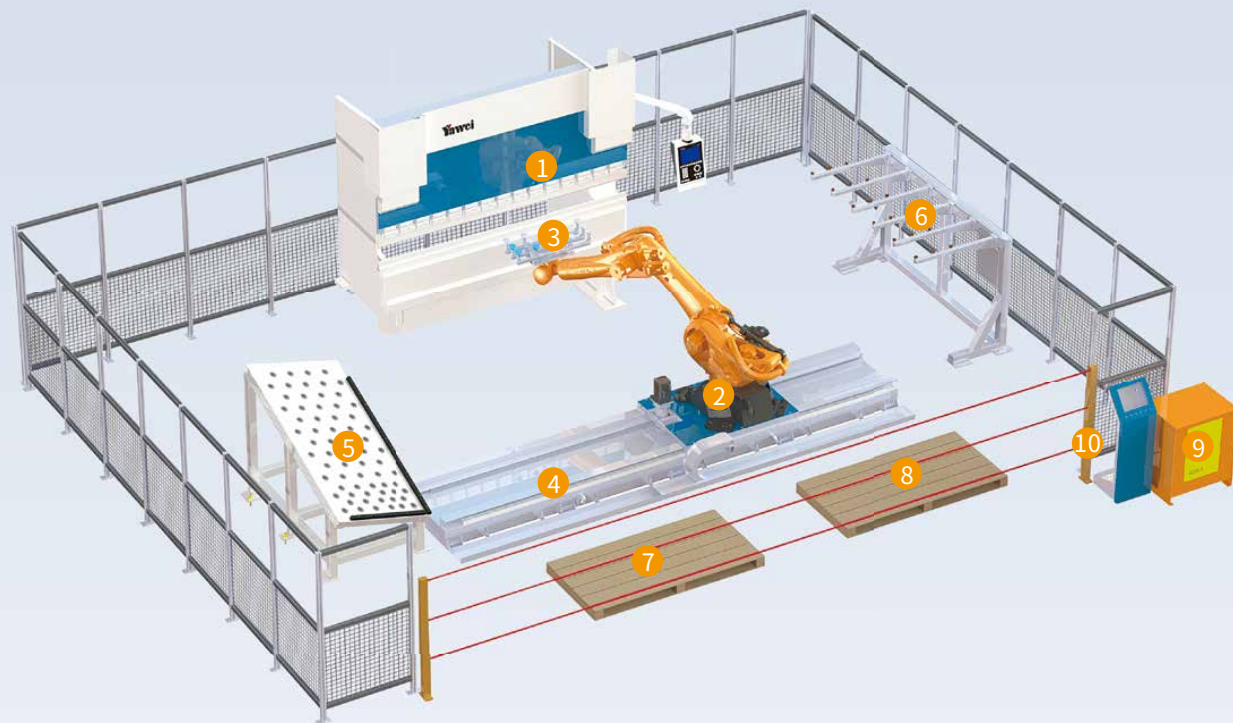

- |          |                            |                     |
|----------|----------------------------|---------------------|
| ① 数控折弯机  | ① CNC Press brake          | ⑥ Turn-over frame   |
| ② 六轴机器人  | ② 6-axis robot             | ⑦ Loading tray      |
| ③ 气动吸盘抓手 | ③ Pneumatic sucker gripper | ⑧ Stacking tray     |
| ④ 移动导轨   | ④ Robot rail               | ⑨ Electrical system |
| ⑤ 对中台    | ⑤ Centering table          | ⑩ Safety protection |
| ⑥ 翻面架    |                            |                     |
| ⑦ 上料托盘   |                            |                     |
| ⑧ 成品堆垛托盘 |                            |                     |
| ⑨ 电气系统   |                            |                     |
| ⑩ 安全防护   |                            |                     |

参数项 Name	单位 Unit	数值 Value
机器人负载 Robot loading capacity	kg	210
机器人轴数 Robot axis		6+1
移动导轨行程 Robot rail stroke	mm	3800
最大工件尺寸 Max. Work piece dimension	mm	3000×1250
最小板厚 Min. Sheet thickness	mm	0.8
最大工件重量 Max. Work piece weight	kg	130
最大板料上料高度 Max. Sheet loading height	mm	400
最大成品堆垛高度 Max. Stacking height	mm	900
相配折弯机系列 Press brake required	PBH-300-4100以下 Below PBH-300-4100	

- |          |          |                            |                     |
|----------|----------|----------------------------|---------------------|
| ① 数控折弯机  | ⑥ 上料托盘   | ① CNC Press brake          | ⑥ Loading tray      |
| ② 龙门机器人  | ⑦ 成品堆垛托盘 | ② Gantry robot             | ⑦ Stacking tray     |
| ③ 气动吸盘抓手 | ⑧ 电气系统   | ③ Pneumatic sucker gripper | ⑧ Electrical system |
| ④ 对中台    | ⑨ 安全防护   | ④ Centering table          | ⑨ Safety protection |
| ⑤ 翻面托架   |          | ⑤ Turn-over frame          |                     |

参数项 Name	单位 Unit	数值 Value
机器人负载 Robot loading capacity	kg	50
机器人轴数 Robot axis		5
最大工件尺寸 Max. Work piece dimension	mm	2000×1000
最小工件尺寸 Min. Work piece dimension	mm	0.8
最大工件重量 Max. Work piece weight	kg	20
最大板料上料高度 Max. Sheet loading height	mm	600
最大成品堆垛高度 Max. Stacking height	mm	1200
相配折弯机系列 Press brake required	PBH-110-4100以下 Below PBH-110-4100	

# 三维五轴激光切割机

3D five-axis laser cutting machine

三维五轴激光切割机是一款专为切割三维金属工件的激光加工设备，主要解决热成形件的切孔和修边问题，其特点是精度高、速度快、性能稳定可靠，配置高性能变位机，可满足行业高效率要求。

3D five-axis laser cutting machine is a laser processing equipment designed for 3D metal workpieces. Specialized in cutting and trimming of hot formed parts, with the advantage of high accuracy, fast speed, stable and reliable performance, and equipped with high-performance positioners, 3D five-axis laser cutting machine can meet the industry's High efficiency requirements.



- 采用高刚性斜拉式悬臂结构，结构紧凑，专门用于热成形件的批量切割
- 机床安全防护符合CE国际安全标准
- HLTD系列加工幅面有3000mm×1500mm、4000mm×2000mm
- 高端配置组合，性能比肩进口设备，更少的成本投入，更低的使用维护成本
- High rigidity cantilevered cantilever structure, compact structure, specially used for batch cutting of hot formed parts
- Machine safety protection complies with CE international safety standards
- HLTD series processing size is 3000mm × 1500mm, 4000mm × 2000mm
- High-end configuration combination, performance can equal to imported equipment, less cost investment, lower maintenance costs



- 德国LTULTRA公司的三维激光切割头，技术先进，质量可靠
- 三维激光加工头具有360°可靠无损的多级防撞保护系统
- 3D laser cutting head from LTULTRA Germany, advanced technology, reliable quality
- The 3D laser machining head has a 360° reliable multi-level anti-collision protection system
- 采用悬臂式床身，结构紧凑开放性好
- 整体性强，刚性好，占地面积小
- Adopt cantilevered frame, compact and open
- Strong integrity, good rigidity and small area coverage
- 除尘双通道设计，可最大限度去除加工过程中产生的有害气体和粉尘
- Double-channel dust removal design, remove the harmful gas and dust generated during the process with maximum efficiency

## 应用行业 Application field



汽车热成形件 Hot forming part of automobile

项目 Items		单位 Unit	数值 Value	
行程 Stroke	X轴行程	X axis stroke	mm	3000
	Y轴行程	Y axis stroke	mm	1500
	Z轴行程	Z axis stroke	mm	650
	C轴转角	Rotating angle of C axis	°	N*360
	A轴转角	Rotating angle of A axis	°	±135
	Q轴行程	Rotating angle of Q axis	mm	±10
速度 Speed	X/Y/Z最大速度	X/Y/Z axis max speed	m/min	100
	X/Y/Z最大加速度	X/Y/Z axis max acceleration	g	1.0
	C/A轴最大速度	C/A axis maximum rotation speed	r/min	120/120
	C/A轴最大加速度	C/A axis maximum rotation acceleration	rad/s <sup>2</sup>	60
精度 Precision	X/Y/Z定位精度	X/Y/Z axis positioning accuracy	mm	±0.05
	X/Y/Z重复定位精度	X/Y/Z axis positioning repeat accuracy	mm	0.03
	C/A轴定位精度	C/A axis positioning accuracy	°	0.015
	C/A轴重复定位精度	C/A axis repeat positioning accuracy	°	0.005



# 三维五轴充气柜激光焊接机

Five-axis laser welding machine

三维五轴激光焊接专机专注解决各种充气柜的三维焊接，具有产品适应面广、效率高等特点；机器长期运行可靠，精度持久不变；模块化设计、通用型备件、全生命周期服务、尽解后顾之忧。

Five-axis laser welding machine Specialized in 3D welding of Inflatable cabinet, with the characteristics of wide product adaptability and high efficiency, reliable long-term operation and stable precision, modular design, universal spare parts, lifetime service.

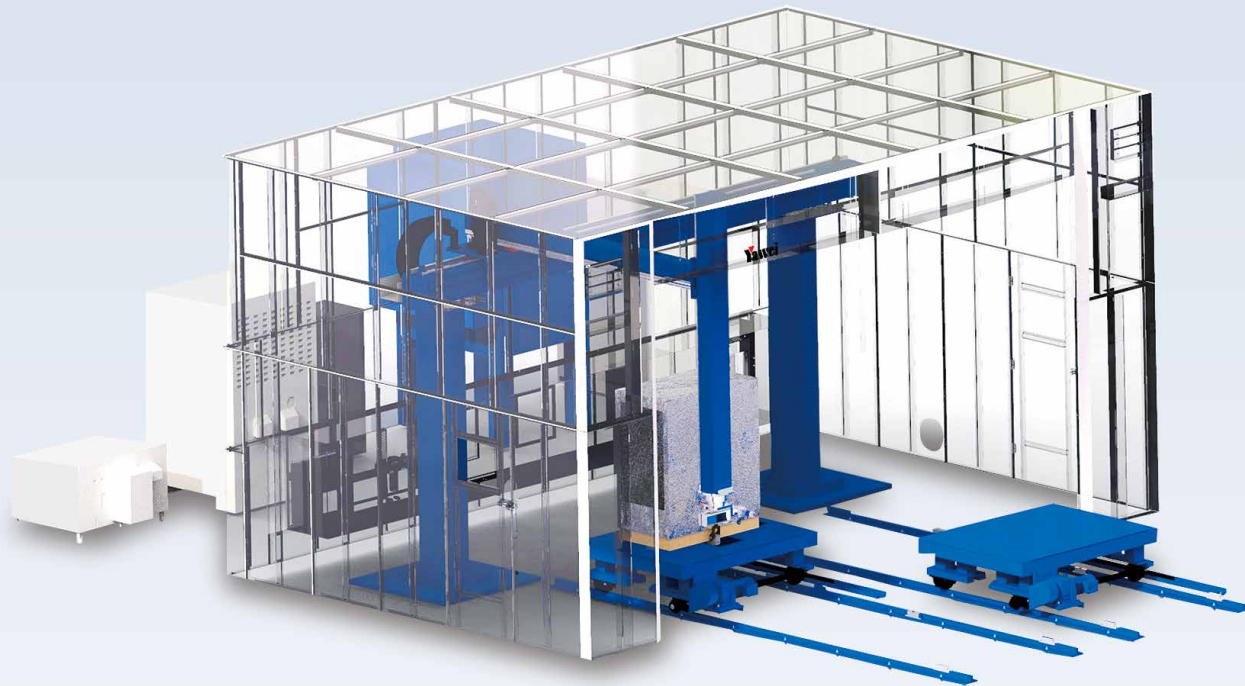

- 机床安全防护符合CE国际安全标准
- 加工幅面4000mm×2500mm，可接受客户定制
- 安装和拆卸区域全开放，方便操作。焊接区域全封闭，保证生产操作人员安全
- 焊接加工区域内架设远程监控用的摄像头，用于对焊接过程的观测
- 双工作台、高速度、高效率
- Machine safety protection complies with CE international safety standards
- The processing size is 4000mm×2500mm, which can be customized
- Installation and disassembly areas are open for easy operation. The welding area is completely closed to ensure the safety of operators
- A remote monitoring camera is installed in the welding processing area to monitor the welding process
- Less cost, easier operation, lower maintenance cost



- 原装进口德国PRECITEC公司的激光焊接头
- 高品质的光学系统和可调整的保护气供给实现高焊接质量，稳定的过程焊接
- The original imported German PRECITEC laser welding head
- High quality optical system and adjustable shielding gas supply to achieve high welding quality, stable process welding



- 采用光纤激光器工业应用的领导者、创新者和最大供应商——德国IPG公司新型先进光纤激光器。广泛应用于各种板材乃至有色金属的加工
- IPG, a leader, innovator and largest supplier of fiber optic lasers, has developed a new advanced fiber optic laser. Widely used in all kinds of plate and non-ferrous metal processing



- 采用德国SIEMENS 840DSL数控系统、搭载网络架构新一代原装驱动器及其伺服电机，独立的CNC控制。备有焊接参数库界面，可在界面中实时修改激光焊接工艺参数及更加智能化的操作功能
- Adopts Germany SIEMENS 840DSL CNC system, equipped with a new generation of network architecture original driver and servo motor, independent CNC control. Equipped with the interface of welding parameters library, the laser welding process parameters can be modified in real time in the interface and more intelligent operation functions



- 采用国际先进的单龙门式直线机器人，可以实现远距离工作空间
- 配合先进的二维自由度旋转模块，可实现焊接头的五轴联动加工
- Using the international advanced single gantry linear robot, can achieve long-distance working
- With advanced 2D rotation module, Five axis linkage machining by welding head can be

## 应用行业-充气柜行业 Application field



	项目 Items	单位 Unit	数值 Value	
行程 Stroke	X/Y/Z轴行程	X/Y/Z axis stroke	mm	4000/2500/2000
	C轴转角	Rotating angle of C axis	°	±210
	A轴转角	Rotating angle of A axis	°	720
速度 Speed	X/Y/Z最大速度	X/Y/Z axis max speed	m/s	2.6/1.8/2.5
	C/A轴最大速度	C/A axis maximum rotation speed	°/s	195
	X/Y/Z重复定位精度	X/Y/Z axis positioning repeat accuracy	mm	±0.02
	C/A轴重复定位精度	C/A axis repeat positioning accuracy	arcmin	1

## 选配-功能部件

Optional-Function Part



### 单列料库+单张取料装置 Single Row Material Library + Single Sheet Feeder Device

单列料库加单张取料装置的搭配模式，能够实现任何库位原材料的导入导出功能，上料机械手直接从出料台车上抓取板料用于与加工设备对接。

Single row material library plus Single sheet feeder device can realize the import and export function of raw materials in any storage location. The loading manipulator directly grabs the sheet from the discharging trolley for docking with the processing equipment.

参数项 Name	单位 Unit	配置1 Configuration 1	配置2 Configuration 2
最大储存板料尺寸 Max. stock sheet size	mm	3000×1500	2500×1250
最小储存板料尺寸 Min. stock sheet size	mm	800×400	800×400
每层最大装载高度 (不含托盘) Max. loading height of each layer (without tray)	mm	300	300
库位数 Library	层数 Layer	6 (可定制Customized)	6 (可定制Customized)
每层最大承载 Max. loading weight of each layer	Kg	3000	3000



### 龙门码垛装置 Gantry Stacking Device

龙门码垛装置可设在各种冲剪、冲割、激光切割或冲压自动化加工系统中，是板料加工线的扩展设备，可配合加工主机自动上料，可对加工出的成品工件进行取件和分区码垛，可与大型板材仓库对接，可与自动化折弯或折边生产线对接。

Gantry stacking device can be installed in various punch & shear combi, punch & laser combi, Laser cutting machine or punch automatic processing systems. It is an extension device for the sheet metal processing line. It can cooperate with the main equipment to realize automatically loading, grab and stack the finished products in different areas. It can be connected with large sheet metal warehouse and automatic bending or panel bender production line.

参数项 Name	单位 Unit	配置 Configuration
加工范围 Processing range		冷轧板、热轧板等 Cold rolled sheet Hot rolled sheet etc
最大加工板料尺寸 Max. processing sheet size	mm	3000×1500
最小工件尺寸 Min. workpiece size	mm	50×100
板材最大厚度 Max. sheet thickness	mm	4
最高码垛高度 Max. stacking height	mm	150

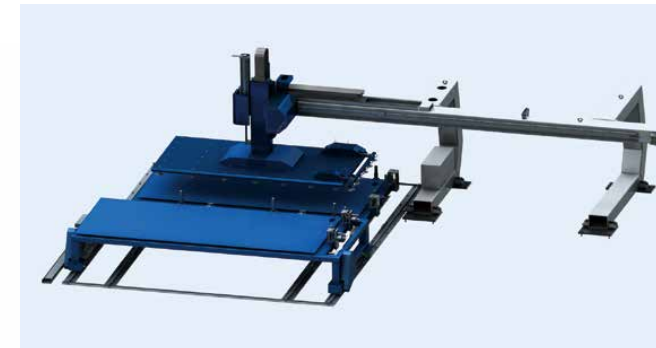

### 龙门式双台车+上料装置 Gantry double trolley + Loading Device

龙门式双台车加常规上料的搭配模式，龙门式双台车可以在上料同一侧装卸板料。在节省了原材料上料耗时的同时减小了对客户场地占地的要求。

Gantry double trolley plus conventional loading, gantry double trolley can load and unload plate materials on the same side. save the time of loading and reduce customer's site occupation.

参数项 Name	单位 Unit	配置1 Configuration 1	配置2 Configuration 2
最大抓取板料尺寸 Max. grab sheet size	mm	3000×1500	2500×1250
最小抓取板料尺寸 Min. grab sheet size	mm	800×400	800×400
最大抓取板料厚度 Max. plate thickness	mm	4	4
上料台车承载 Max. load on loading trolley	kg	3000	3000
上料台车最大堆高 Max. height on loading trolley	mm	220	220
台车移动速度 Trolley movement speed	m/min	20	20

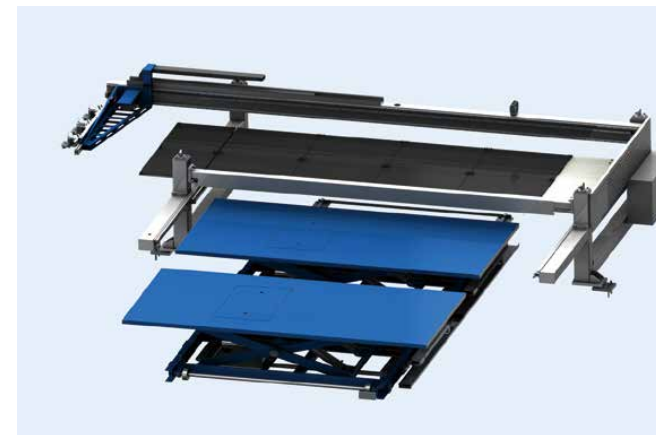

### 双升降台车+下料装置 Double Lifting Trolley+ Unloading Device

下料装置加双下料升降台车的搭配模式，下料升降台车可以分别开至下料装置两侧卸料。节省了客户对半成品卸料所占用的停机时间。

Unloading device with double unloading lifting trolley. Unloading lifting trolley can discharge sheets to both sides of unloading device, which can shorten the breakdown time of semi-finished products discharging.

参数项 Name	单位 Unit	配置1 Configuration 1	配置2 Configuration 2
最大下料板料尺寸 Max. Discharge size	mm	3000×1500	2500×1250
最小下料板料尺寸 Min. Discharge size	mm	800×400	800×400
最大下料板料厚度 Max. Discharge thickness	mm	4	4
下料升降台车承载 Max. Weight on unloading trolley	Kg	3000	3000
下料升降台车最大堆高 Max. Height on unloading trolley	mm	220	220
台车移动速度 Trolley speed	m/min	20	20



## 选配-功能部件

Optional-Function Part

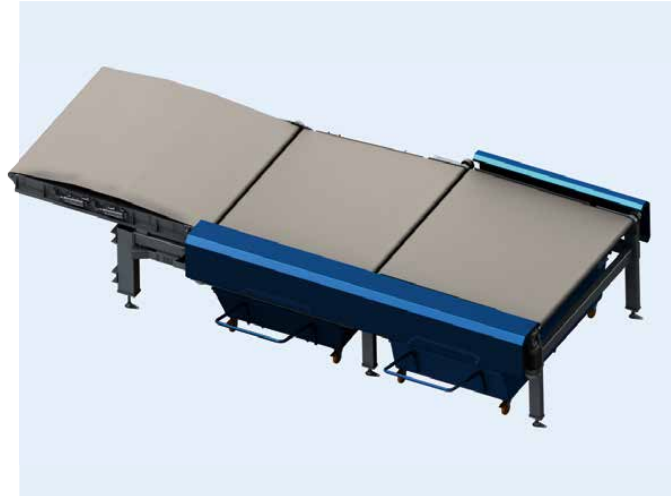

### 冲剪系统用分拣下料 Sorting and Blanking Device for Punch & Shear System

传送带式分选落料，用于直角剪之后，落料剪切下料的工件。  
Conveyor type sorting device, locating after right angle shearing machine, is used to sort the sheared work pieces.

- 传送带式分选落料系统，用于分选落料剪切下来的工件
- 标配两级，可选配多级，由控制系统自动分选落料
- 分选零件尺寸可达到800x1500mm
- 分选速度快，工件传送平稳

- Conveyor type sorting device is used to sort the sheared work pieces
- Standard two-stage sorting device, optional multi-stage sorting device. Sorting automatically controlled by controller
- Max. Part size up to 800x1500mm
- Fast speed sorting, and smooth conveying



### 冲剪系统用自动分选堆垛装置 Punch and Shear System with Automatic Sorting Stacking Device

- 对开辊子式的自动分选码垛装置
- 自动分选堆垛剪切下来的工件至特殊的交互台车上
- 更快的零件传送，更快的堆垛位置改变，更快的堆垛周期，更强的布局规划能力
- Roller type automatic sorting stacking
- Automatically sort the sheared pieces to a special interactive trolley
- Faster parts delivery, rapid stacking, shorter cycle time, stronger layout planing ability

参数项 Name	单位 Unit	配置1 Configuration 1	配置2 Configuration 2
最大堆垛板料尺寸 Max. Stacking size	mm	4500x1500	3000x1500
最小堆垛板料尺寸 Min. Stacking size	mm	400x100	400x100
最大堆垛高度 Max. Stacking height	mm	140	140

## 选配-功能部件

Optional-Function Part

### 选配项 Optional Parts



#### 机器人抓手快换装置 Robot Gripper Fast Exchanging Device

机器人抓手快换装置通过使机器人自动更换不同的吸盘抓手，使机器人的应用更具柔性。抓手快换装置包括一个主盘用来安装在机器人手臂末端法兰盘上，还包括多个工具盘用来安装各个不同的抓手。

- 机器人抓手更换可以在数秒内完成，大大降低停工时间
- 通过在应用中使用1个以上的抓手，从而使柔性增加
- 根据机器人的负载可选择相应负载的抓手快换装置

With the gripper fast changing device, the robot can change the pneumatic gripper automatically. Thus make the robot application more flexible. The gripper fast changing device includes one main plate locates on the flange that at the end of robot arm. And many tool plates to install variety grippers.

- Robot gripper changing can be finished in few seconds, which can short the breakdown time greatly
- Using more than one grippers to make the system more flexible
- The loading capacity of gripper can be chosen according to the loading capacity of robot

#### 机器人视觉定位装置 Robot Visual Positioning Device

通过视觉产品（光源、镜头、相机、采集卡）引导机器人自动变换抓手位置，精确抓取工件，实现机器视觉与机器人之间通讯以及坐标系转换。

- 采用C#，VisionPro软件开发的定制化操作界面，运行效率高
- COGNEX 500W像素，工业CCD
- 定位精度 0.5mm-1mm
- 识别工件范围 1000mmx750mm

With help of visual devices (e.g. Optical source, camera, collecting card), the robot will able to change the gripper locations automatically, grab the work piece accurately, and realize the communication and axes converting between machine visualization and robot.

- Customized operation interface developed by C#, VisionPro software can achieve higher running efficiency
- COGNEX 5 million pixels, Industry CCD
- Positioning accuracy 0.5mm-1mm
- Work piece recognition range 1000mmx750mm





## 电气行业 客户案例

Electric Industry Customer Installations

## 电梯行业 客户案例

Elevator Industry Customer Installations



北京龙源电气  
Beijing Long Yuan Electric



天翔电气  
Tian Xiang Electric



广州菱王  
Guangzhou Winone



广州广日  
Guangzhou Guang Ri



江苏荣威电气  
Jiangsu Rong Wei Electric



宁夏力成  
Ningxia Li Cheng



上海中联  
Shanghai Zhong Lian



兰州伊士顿  
Lanzhou Yi Shi Dun



天水长城  
Tianshui Greatwall



深圳泰豪科技  
Shenzhen Tai Hao Tech



徐州永日  
Xuzhou Yong Ri



北京优视  
Beijing You Shi



# 环保设备行业 客户案例

Environmental Protection Equipment Industry Customer Installations

# 幕墙行业

Curtain Wall Industry



江苏宝丽洁  
Jiangsu Borage



安徽辰航  
Anhui Chen Hang



上海合富  
Shanghai Tri-win



重庆恒亚  
Chongqing Heng Ya



江苏一驰  
Jiangsu Yi Chi



上海马尔斯  
Shanghai Maars



# 家电行业 客户案例

Household Appliance Industry Customer Installations

# 其它行业

Other Industry



长沙格力  
Changsha Gree

南京熊猫电子  
Nanjing Panda Electric



郑州精益达 (汽车)  
Zhengzhou Jing Yi Da(Automobile)



宁波吉盛 (厨具)  
Ningbo Jie Sheng(Kitchen Ware)



青岛马士基 (集装箱)  
Qingdao Maersk(Container)



安徽浦菲尔 (门业)  
Anhui Pfier (Door trade)



山东临工 (工程机械)  
Shandong Lin Gong(Construction Machinery)



河南万华 (畜牧)  
Henan Wanhua(Farming)



江苏亚威机床股份有限公司  
JIANGSU YAWEI MACHINE TOOL CO., LTD.

中国

江苏扬州市江都区黄海南路仙城工业园

邮编: 225200

销售电话: 0514-86880518 86880528 86519118

售后服务: 0514-86880538 86519128 86519158

配件销售: 0514-86519148

传真: 0514-86882218 86519188

网址: www.yawei.cc

电邮: sales1@yawei.cc

INTERNATIONAL

XIANCHENG INDUSTRIAL ZONE, HUANGHAI SOUTH ROAD

JIANGDU DIST. 225200 YANGZHOU, JIANGSU, CHINA

Sales hot line: +86-514-86880517 +86-514-86880518

Service phone: +86-514-86880517 +86-514-86880538

Part sales phone: +86-514-86519148

FAX: +86-514-86880521 +86-514-86882218

HTTP: www.yawei.cc

Email: sales2@yawei.cc



以上两个标志皆为江苏亚威机床股份有限公司的商标  
The above two marks both are commercial brand of Jiangsu Yawei Machine Tool Co., Ltd.

产品不断改进, 样本如有变动恕不另行通知  
The contents are subject to change without prior notice



亚威公众微信  
YAWEI WeChat